

## HT8 Key Design Features

1. Multi-speed control panel providing both on/off switching of the floor sander and the choice of four operating speeds in a simple, easy to use configuration.
2. Optional disposable paper bags for efficient and safe dust collection. Manufactured from recycled materials, Hiretech disposable paper dust bags are the environmentally friendly way to handle and dispose of the dust created during the sanding process.
3. High powered vacuum system, with seated oversize wide bladed alloy vacuum fan and adjustable dust pan. In combination with Hiretech disposable paper dust bags, dust collection is very efficient improving the operating environment and minimising clean-up time.
4. Polished aluminium alloy body.
5. ABS side guards help prevent damage to walls and skirtings.
6. Four pole motor provides powerful performance with constant drum speed across the whole range of abrasive grits and motor speeds.
7. Long lasting non-slip toothed drive belts with precision gear cut pulleys.
8. Dynamically balanced 203mm (8") wide sanding drum, aluminium extrusion and high performance drum rubber with stainless steel backing.
9. Patented reversible drop forged paper clamp bar with clamp bar screws and lifting pin system.
10. Precision moulded brush block with brass brush holders and constant force brush springs.
11. Adjustable handle provides ideal height for perfect control and feel.
12. 7m (23') power cable with non-marking outer insulation prevents marking of newly sanded floor.

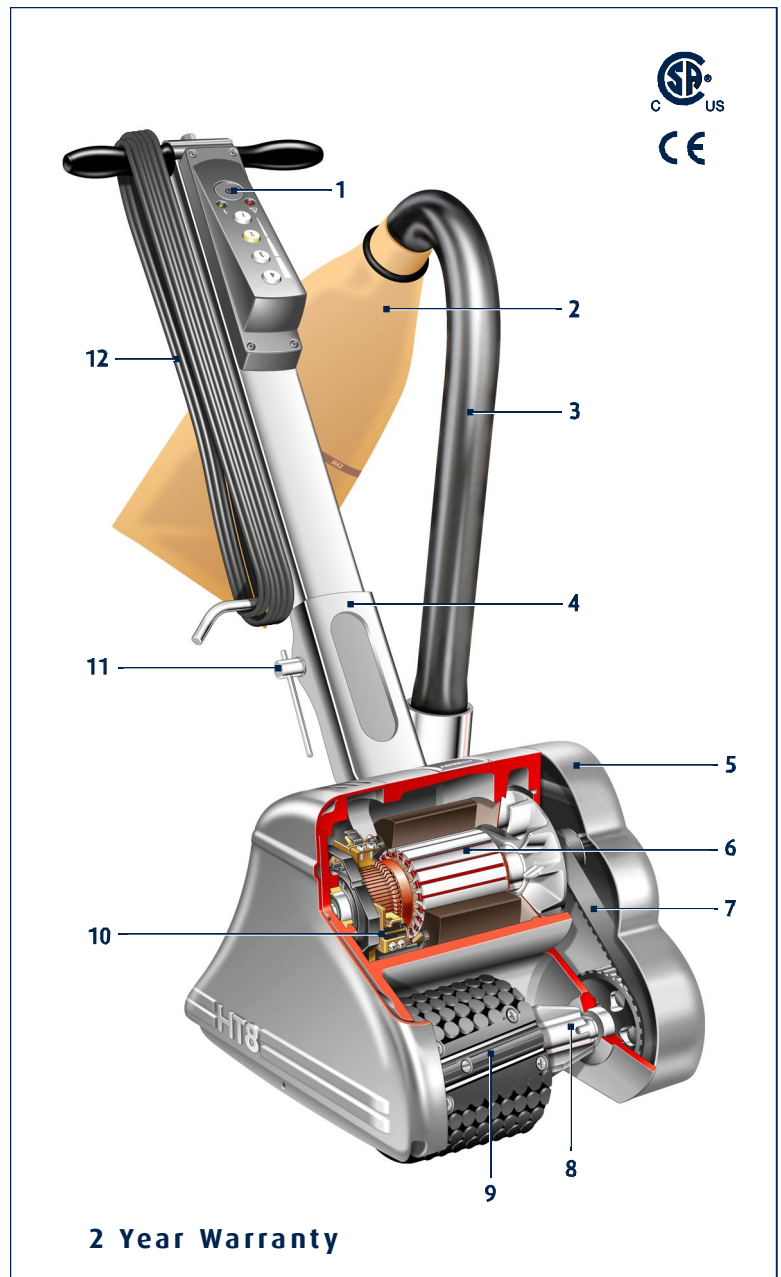

### Technical Specifications

Product Codes	: 07005 (220/250V), 07006 (110/120V)
Off Load Current	: 220/250V = 5A, 110/120V = 8A
Av. Load Current	: 220/250V = 8A, 110/120V = 15A
Switch	: Multi-Speed Control, No Volt Start Protection
Motor RPM	: 8,500 / 7,300 / 6,900 / 6,500
Drum RPM	: 3,300 / 2,800 / 2,650 / 2,500 (off load)
Sanding Drum	: 200mm (8")
Abrasive	: Notched and angled ends P24 to P120
Weight Net	: 41.5kg (91.5lbs)
For detailed technical specifications see page 19	

