

# **HIRETECH<sup>®</sup>**

[www.hiretech.biz](http://www.hiretech.biz)

## **HT8 & HT8 EX MULTI-SPEED CONVERSION KIT**



PRINTED IN THE UK

**SUPPLEMENTARY OWNERS MANUAL & OPERATING INSTRUCTIONS**

## SPECIFICATION

The Hiretech Multi-Speed control provides both on/off switching of the floor sander and the choice of four operating speeds in a simple, easy to use configuration. Additional functionality comes in the form of 'no volt start' that prevents accidental start-up when the power cord is connected to the power supply. Motor stall protection, operating within just 1.5 seconds of a stall event. Motor overload protection and run-time management provided by service indicator lights via the four speed-selector buttons.

The Hiretech Multi-Speed control fits all models of Hiretech floor sanders HT8, HT8 EX, DU8 and DU8R.

For safety and operating instructions please refer to the Owners Manual & Operating Instructions originally supplied with your Hiretech floor sander.

Please keep this Supplementary Owners Manual & Operating Instructions together with your original Owners Manual.

<b>Power Supply:</b>	110/120 V 50/60 Hz 220/240 V 50/60 Hz
<b>Off Load Current:</b>	110/120 V 8A 220/250 V 5A
<b>Average Load Current:</b>	110/120 V 15A 220/250 V 8A
<b>Noise:</b>	95 dBa at 1 metre (3' 3")
<b>Vibration:</b>	1.60 m/s <sup>2</sup> r.m.s.
<b>Switch:</b>	Electronic On/Off switch and multi-speed control with no volt start and overload protection
<b>Motor:</b>	Continuous heavy duty AC/DC self cooling 4 brush.
<b>Motor RPM:</b>	Multi-speed user selected 8,500/7,300/6,900/6,500
<b>Drum RPM:</b>	Multi-speed user selected 3,300/2,800/2,650/2,500
<b>Warranty:</b>	1 year

### HT8 EX MULTI-SPEED ABRASIVE & SPEED APPLICATION CHART

Abrasive Grit	Application	Speed Setting			
		1	2	3	4
Extra Coarse P16 to P24	For heavy sanding, stripping and levelling of floors in poor condition, fast stock removal, removal of heavy deposits of wax and dirt.			✓	✓
Coarse P30 to P50	For general sanding, stripping and levelling of floors in poor to average condition, levelling of most floor types. In progression from extra coarse grit abrasives.		✓	✓	✓
Medium P60 to P80	Light sanding and stripping of floors in average condition. First sanding of floors previously sanded in need of renovation. In progression from coarse grit abrasives.	✓	✓	✓	✓
Fine P100 to P150	Fine sanding for floors in good condition in need of maintenance. For progression to final sanding from medium grit abrasives. For progression to extra fine sanding with an orbital floor sander.	✓	✓	✓	✓

## OPERATION

To switch on lightly press and hold the ON/OFF button (I/O) until the motor starts (approximately 1.5secs) then release the button.

To switch off lightly press the ON/OFF button (I/O) and the HT8 will switch OFF.

Select one of the four operating speeds by pressing one of the four buttons marked 1, 2, 3 or 4. 1 is the slowest speed, 4 is the fastest speed. See the Multi-Speed Abrasive and Speed Application Chart on page below for recommend speeds and applications.

The user may pre-select the operating speed before switching ON.

## SERVICE & ROUTINE MAINTENANCE



**CAUTION** - maintenance and repairs must be carried out by authorised personnel only. To prevent injury, always remove the power cable from the power supply before undertaking any work on the machine. Do not operate the floor sander unless it is fully assembled and all guards are in place. Use Hiretech genuine spare parts only.

### HT8 Multi-Speed Service Indicator Light

- To help assist in scheduling routine servicing and maintenance the HT8 Multi-Speed has a run time clock built into the Multi-Speed Control Unit. The run time clock records the time the HT8 motor runs and stores the total run time in memory even when the HT8 is disconnected from the power supply.

Two run time intervals of 100hrs or 300hrs can be set by the operator. When the run time interval set is reached the 'green' power connected light flashes 4 times when the HT8 is first connected to the power supply. The light will then remain ON to indicate that power is connected (see illustration on page 3).

The run time can not be reset until the interval set (100hrs or 300hrs) has been reached. The green power connected light will only flash when the power is first connected and the set number of run time hours has been reached. At all other times the green power connected light will come ON without flashing when the power supply is connected.

From new the run time clock is set to indicate 300hrs of run time. When this pre-set time is reached the green power connected light will flash when the power is connected.

On completion of any service work the run time clock maybe reset to 300hrs or 100hrs at the owners/operators discretion.

It is recommend that if the HT8 is owner operated that the run time is reset to 100hrs after the initial 300hr run time until new motor brushes are fitted. When new motor brushes are fitted it is recommended the run time is reset to 300hrs.

If the HT8 is part of a hire or rental fleet it is recommend that the run time is reset to 100hrs at all times to provide for more regular servicing as demanded by the hire and rental market.



**CAUTION** - the run time indicator is provided as a reminder to the operator/workshop that the HT8 requires a 'full' service paying particular attention to the service areas detailed on the Owners Manual. Routine maintenance should be carried out on a regular basis with special attention paid to guards, cables and general mechanical components.

Note: When a new Multi-Speed Handle Assembly or new Multi-Speed Control unit is fitted carry out a full service including replacing all four motor brushes. This service will then match the initial 300hrs service interval as set from the factory.

## HT8 MULTI-SPEED CONTROL UNIT (SWITCH)

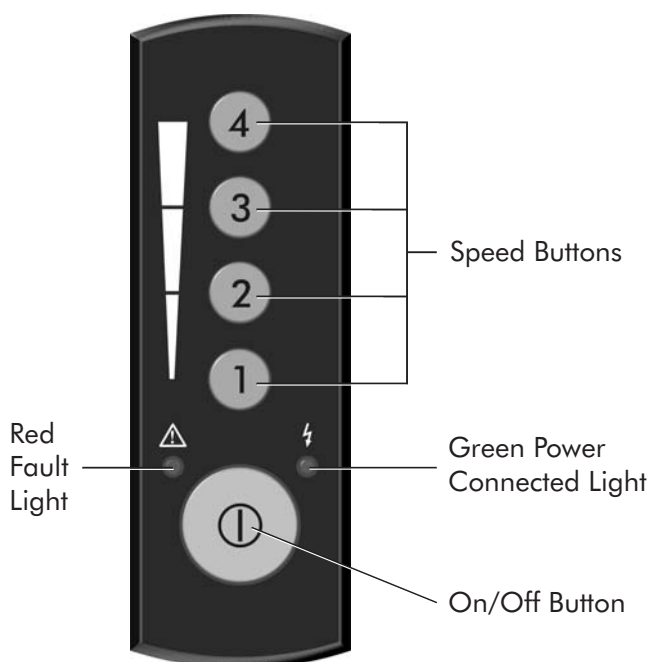

2. To reset the run time clock to 300hrs connect the HT8 to the power supply. DO NOT start the HT8. With the power connected and the green power connected light ON, press and hold Speed Buttons 2, 3 and 4 together for a minium of 3 seconds. Speed Button 3 light will flash to indicate that the run time clock has been reset to 300hrs.

Release the Speed Buttons, button 1 will now be ON (yellow light). Disconnect from the power supply, then reconnect to check that the green power connected light does not flash when connecting to the power supply to confirm the reset has been successful.

3. To reset the run time clock to 100hrs connect the HT8 to the power supply. DO NOT start the HT8. With the power connected and the green power connected light ON, press and hold Speed Buttons 1, 2 and 4 together for a minium of 3 seconds.

### Multi-Speed Control Unit (Switch)



**CAUTION** - there are no serviceable components in the HT8 Multi-Speed Control Unit. Under no circumstances must any parts be serviced or tampered with. If the unit fails to operate contact your local reseller. Replacement parts must be fitted by a qualified electrician.

### Fitting a new Switch Multi-Speed (Ref.7)

1. To replace the Switch Multi-Speed Ref.7 remove the four Screws Ref.86 from the Switch Housing Ref.11. Carefully lift the Switch Housing clear of the Handle Tube Ref16. Take care to avoid damage to the rubber 'O' ring Gasket Switch Housing Ref.10.
- The Switch Multi-Speed Ref.7 is connect to the Controller Multi Speed Ref.9 via a ribbon cable. Take care not to stretch or pull this cable.
2. Carefully disconnect the ribbon cable from the Controller Switch Multi-Speed Ref.9 by pushing the two end clips outwards.
3. Remove the six Screws Ref.8 from the Switch Multi-Speed and remove the component from the Switch Housing.
4. Place the new Switch Multi Speed in the Switch Housing and secure using the six Screws Ref.8. Do not over tighten the screws.
5. It is recommended that a new Gasket Switch Housing Ref.10 is fitted. Carefully place the Gasket in the rebate on the back of the Switch Housing.

6. Reconnect the ribbon cable to the Controller Multi-Speed. Ensure that the connection is free of dust, carefully align the ribbon cable plug and push down until the two end clips lock into position.
7. Place the Switch Housing on the Handle Tube taking care not to trap the ribbon cable or dislodge the Gasket Switch Housing.
8. Replace the four Screws Ref.86.
9. Carry out electrical and function tests (see below).

### Fitting a new Controller Multi-Speed (Ref.8)

Note: Refer to the Circuit Diagram on page 19.

1. To replace the Controller Multi-Speed Ref.9 remove the four Screws Ref.86 from the Cover Switch Ref.11. Carefully lift the Cover Switch clear of the Tube Handle Ref.16. Take care to avoid damage to the rubber 'O' ring Gasket Ref.10 The Switch Multi-Speed Ref.7 is connected to the Controller Multi-Speed via a ribbon cable. Take care not to stretch or pull on this cable.
2. Carefully disconnect the ribbon cable from the Controller Ref.9 by pushing outwards on the two end clips positioned each side of the ribbon cable socket. Place the Cover Switch Assembly to one side.
3. Disconnect the Cable Main Ref.39 and remove it together with the Strain Relief Ref. 5 Release the Cable Handle Strain Relief Ref.18 and remove the Earth (Ground) Terminal from the Cable Handle termination at the top of the Tube Handle Ref.16).
4. Remove the 6 Screws and Washers Ref.12 from the back of the Tube Handle to release the Controller Ref.9 You will note that the controller appears to be 'stuck' into position, this is due to the 'Heat Sink Compound used to ensure good thermal contact between the two components. Carefully lever the two components apart taking care not to damage the Tube Handle Ref.16.
5. Disconnect the Cable Handle to Motor Output Terminals and remove the controller.
6. Thoroughly clean the inside of the Tube Handle Ref.16 ensuring the all traces of the old Heat Sink Compound are removed.
7. Carefully apply a thin layer of Heat Sink Compound Ref.13 to the back of the new Controller. Take care to ensure only a very thin layer is applied evenly over the entire rear surface, do not over apply.
8. Connect the Cable Handle to Motor Output

Terminals and position the two AC cables alongside the controller so that they will be available for connection later. (see diagram on page 19).

9. Carefully place the new controller into position taking care to line up the 6 mounting holes with the holes in the Tube Handle, secure it into position with the 6 Screws and Washers Ref.12.
10. Carefully following the Diagrams reconnect the Cable Main and the Earth (Ground) Terminal from the Cable Handle, taking care to correctly fit the two Strain Reliefs Refs. 5 and 18 to ensure that the cables are properly secured.
11. Examine the Cover Switch Assembly, if the 'O' ring Gasket Ref.10 is damaged in any way replace it by carefully placing the new gasket into position in the groove provided on the underside of the Cover Switch Ref.11 You may find that using a little adhesive such as 'super glue' will help hold the gasket into position during re-assembly.
12. Reconnect the Switch ribbon cable to the controller by pushing it into position and noting that the two clips positioned at each side of the socket lock inwards securing the ribbon cable plug.
13. Place the Cover Switch Assembly onto the Tube Handle and line up the four mounting holes, taking care to avoid trapping any leads or dislodging the Gasket. Secure it into position with the 4 screws Ref.86
14. Carry out electrical and function tests (see below).

### Electrical Testing



*CAUTION - testing for electrical safety should be undertaken by a competent person and all results recorded. Do not exceed 1250 volt insulation test duration of 3 seconds.*

1. Examine the power cable and handle cable for damage, if the outer insulation shows more than the slightest of abrasions or the inner conductors are exposed then the cable must be replaced. The cables must not be repaired with tape or insulation sleeve.
2. Open and check mains plug and interconnecting socket Ref.24 for condition, loose connections, damaged wires etc. Ensure that the strain relief of the power cable plug is correctly secured to the outer cable insulation.

3. Open and examine the Switch Housing Ref.11 for loose connections, damaged wires, and general condition. Pay special attention to any gaskets, 'O' rings and seals intended to exclude dust from the switch and switch housing area, these must be maintained in good condition.
4. Ensure that the Strain Relief Ref.5 is correctly secured to the outer cable insulation.
5. For the HT8 fitted with a Multi-Speed Control and HT8's fitted with a low volt circuit breaker type switch use a trailing test cable (see part information below) that connects the testing equipment directly to the machine body Base Twist Lock Ref.23 This allows the body of the HT8 to be tested separately from the handle assembly.

Part No. 024500 Test Lead  
(use for all regions excluding North America)

Part No.:024502 Test Lead (NA)  
(use for North America only)



*CAUTION - the HT8 Test Lead does not have the LIVE (HOT) conductor connected. Only the NEUTRAL and EARTH are connected at the plug end and the NEUTRAL AND EARTH connected at the Body Twist Lock end. There is also a shunt fitted in the body twist lock to short the LIVE and NEUTRAL terminals to allow a full dielectric test. THIS TRAILING TEST LEAD CANNOT BE USED FOR FUNCTIONAL TESTING.*

6. Replace the switch cover taking care to avoid trapping leads and ensuring that the dust gasket is correctly positioned.
7. Place the handle assembly on the test bench then using standard procedure test for electrical safety (CLASS 1 EARTHED APPLIANCE)

DO NOT EXCEED 1250 VOLT FLASH DURATION 3 SECONDS.

RECORD THE TEST RESULTS.

8. Now Place the machine body safely on the test bench and connect the Test Lead to the Base Twist Lock Ref.23 and connect the other end to the test equipment. Then using standard procedure test for electrical safety.(CLASS 1 EARTHED APPLIANCE)

DO NOT EXCEED 1250 VOLT FLASH DURATION 3 SECONDS.

RECORD THE TEST RESULTS.

9. You have now tested both the handle assembly and the machine body, if both show good test

results then you can carry out a functional or run test if required by placing the complete machine in a secure position and switching the machine on.



*CAUTION - when undertaking a functional test ensure that the machine is secure, remember the sanding drum will rotate, ensure that the drum cannot come into contact with the work bench/service area.*

10. Ensure that the switch trips to 'OFF' when the current is interrupted. During complete machine functional test with the machine switched on and running. Switch off the electrical supply at the supply socket then when the machine has stopped - switch it back on at the socket. Note that the machine has tripped to OFF and the speed button one (1) is illuminated. You must now press and hold the ON/OFF (I/O) button for 1.5secs to turn the machine ON.

If this function fails to operate do not use the machine. Report/repair fault and retest.

#### MULTI-SPEED FAULT INDICATOR LIGHT STATUS

Condition	Flashes
Overload	1
Over Temperature	2
Under Voltage	3
Ribbon Cable Fault	4
Frequency Fault (110/120V only)	5

The red fault indicator light will flash approximately 40 times per minute in groups of 1 to 5 flashes as detailed above to provide diagnostic information.

MANUFACTURED BY  
**HIRE TECHNICIANS GROUP LIMITED**  
**CHALK HILL HOUSE, 8 CHALK HILL, WATFORD,**  
**HERTS, WD19 4BH. UNITED KINGDOM**

**TEL: +44 (0)1923 332424**  
**FAX: +44 (0)1923 332425**  
**E-mail: sales@hiretech.biz Web:**  
**www.hiretech.biz**

# HT8 MULTI-SPEED PARTS DIAGRAM & PARTS LIST

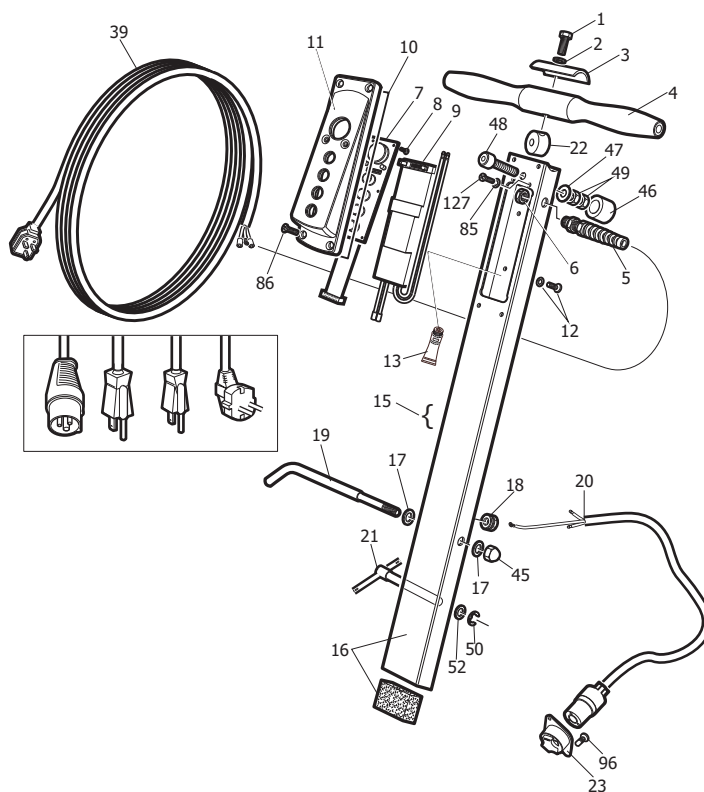

Ref.	PSTK	Pack Qty.	Description
001	962308	1	Screw
002	980652	2	Washer
003	162019	1	Clamp Handle
004	163907	1	Handle Cross
005	101205	1	Strain Relief
005	163691	1	Strain Relief (NA)
006	101206	1	Nut Lock
007	024520	1	Switch Multi-Speed
008	024615	6	Screw
009	024525	1	Controller Switch Multi-Speed 240 Volt
009	024530	1	Controller Switch Multi-Speed 110 Volt
010	163870	1	Gasket Switch Housing
011	024510	1	Cover Switch Multi-Speed
012	024620	6	Screw and Washer Set
013	007633	1	Heat Sink Compound
015	020300	1	Multi-Speed Conversion Kit HT8/DU8 240 Volt (UK)
015	020305	1	Multi-Speed Conversion Kit HT8/DU8 110 Volt (UK)
015	020310	1	Multi-Speed Conversion Kit HT8/DU8 220 Volt (EUR)
015	020315	1	Multi-Speed Conversion Kit HT8/DU8 240 Volt (AUS)
015	020320	1	Multi-Speed Conversion Kit HT8/DU8 110 Volt (NA)
016	169015	1	Tube Handle Multi-Speed
017	980615	2	Washer
018	101220	1	Strain Relief Handle Cable
018	163804	1	Strain Relief Handle Cable (NA)

Ref.	PSTK	Pack Qty.	Description
019	164508	1	Hook Cable
020	024560	1	Cable Handle Multi-Speed
020	024575	1	Cable Handle Multi-Speed 110 Volt (UK)
020	024580	1	Cable Handle Multi-Speed (NA)
021	960180	1	Clamp Handle Bracket
022	960183	1	Bracket Handle Cross
023	911045	1	Base Twist Lock
039	024540	1	Cable Main Assembly Multi-Speed 240 Volt (AUS)
039	024545	1	Cable Main Assembly Multi-Speed 220 Volt (EEC)
039	024550	1	Cable Main Assembly Multi-Speed 110 Volt (UK)
039	024555	1	Cable Main Assembly Multi-Speed 110 Volt (NA)
039	908285	1	Cable Main Assembly Multi-Speed 240 Volt (UK)
045	920148	1	Nut
046	024600	1	Buffer Rubber
047	980197	1	Washer
048	024605	1	Bolt
049	030850	2	Nut
050	167308	1	Ring Retaining
052	980196	1	Washer
085	980623	2	Washer
086	962109	8	Screw
096	010210	4	Screw
127	962345	10	Screw